

Kramer Electronics, Ltd.



USER MANUAL

Model:

SP-11D

Digital Video Processor

Contents

1	Introduction	1
2	Getting Started	1
3	Overview	1
4	Your SP-11D Digital Video Processor	2
5	Installing on a Rack	6
6	Connecting Your SP-11D Digital Video Processor	7
6.1	Connecting a PC	8
6.2	Dipswitch Settings	8
7	Operating the SP-11D Digital Video Processor	10
7.1	Storing/Recalling Setups	12
7.2	Locking the Front Panel	12
8	Technical Specifications	13
9	Communication Protocol	14

Figures

Figure 1: SP-11D Digital Video Processor	3
Figure 2: Connecting a PC without using a Null-modem Adapter	8
Figure 3: Connecting the SP-11D Digital Video Processor	9

Tables

Table 1: Front Panel SP-11D Digital Video Processor	4
Table 2: Rear Panel SP-11D Digital Video Processor	5
Table 3: Dipswitch Settings	8
Table 4: Test Signals	9
Table 5: Technical Specifications of the SP-11D Video Processor	13
Table 6: Protocol Definitions	14

1 Introduction

Welcome to Kramer Electronics (since 1981): a world of unique, creative and affordable solutions to the infinite range of problems that confront the video, audio and presentation professional on a daily basis. In recent years, we have redesigned and upgraded most of our line, making the best even better! Our 350-plus different models now appear in 8 Groups¹, which are clearly defined by function.

Congratulations on purchasing your Kramer **SP-11D Digital Video Processor**. This product is ideal for:

- Video broadcasting and editing studios
- All postproduction uses
- Presentation applications for multi-standard / multi-format sources use

The package includes the following items:

- **SP-11D Digital Video Processor**
- Power cord and Null-modem adapter
- This user manual²

2 Getting Started

We recommend that you:

- Unpack the equipment carefully and save the original box and packaging materials for possible future shipment
- Review the contents of this user manual
- Use Kramer high performance high resolution cables³

3 Overview

The unique **SP-11D** is a multi-standard / multi-format broadcast-quality video processor – ProcAmp, TBC, format converter (for mixing different types of equipment), and standards converter. It is a universal single-box solution for all your video processing requirements.

In particular, the **SP-11D Digital Video Processor** includes the following:

1 GROUP 1: Distribution Amplifiers; GROUP 2: Video and Audio Switchers, Matrix Switchers and Controllers; GROUP 3: Video, Audio, VGA/XGA Processors; GROUP 4: Interfaces and Sync Processors; GROUP 5: Twisted Pair Interfaces; GROUP 6: Accessories and Rack Adapters; GROUP 7: Scan Converters and Scalers; and GROUP 8: Cables and Connectors

2 Download up-to-date Kramer user manuals from the Internet at this URL: <http://www.kramerelectronics.com>

3 The complete list of Kramer cables is on our Web site at <http://www.kramerelectronics.com>

- Inputs: Composite video, s-Video, Component video (YUV or RGB/S), SDI, and Genlock
- Outputs¹: Composite video, s-Video, Component video (YUV, RGB, RGBS, RGBHV), SDI (2 outputs), “Before/after” split-screen, and Genlock loop
- Video Standards²: PAL-B/D/G/H/I/M/N, NTSC-3.58/4.43, SECAM
- ProcAmp functions: video gain, brightness, contrast, color, hue, and sharpness (independent H and V)
- A full range of color control features in both YUV and RGB colorspaces³
- Four-field memory for the highest picture quality
- Timing: Genlocked to an external video reference with control of H-delay and SCH phase. Alternatively, the unit can synthesize its own timing to provide a full time-base-corrected (TBC) output
- Individual H and V Chroma – Luma delay

In addition, the **SP-11D Digital Video Processor** includes:

- 16 non-volatile memory setups that are available for saving the settings
- Powerdown save, Picture freeze, and a screen splitter that provides simultaneous "before and after" image comparison on one monitor
- Full 10-bit digital processing throughout, for the highest possible video quality

Control the **SP-11D**:

- Using the front panel buttons and the 7-segment display
- Remotely, by RS-232 serial commands transmitted by a touch screen system, PC, or other serial controller

To achieve the best performance:

- Connect only good quality connection cables, thus avoiding interference, deterioration in signal quality due to poor matching, and elevated noise levels (often associated with low quality cables)
- Avoid interference from neighboring electrical appliances that may adversely influence signal quality and position your **Kramer SP-11D** away from moisture, excessive sunlight and dust

4 Your SP-11D Digital Video Processor

Figure 1, Table 1, and Table 2 define the **SP-11D Digital Video Processor**.

1 All output formats are always available

2 The SP-11D can be used for conversion to any video standard

3 RGB and YUV inputs, RGB and YUV outputs, and independent control of RED, GREEN and BLUE; and Y, R-Y and B-Y

Your SP-11D Digital Video Processor

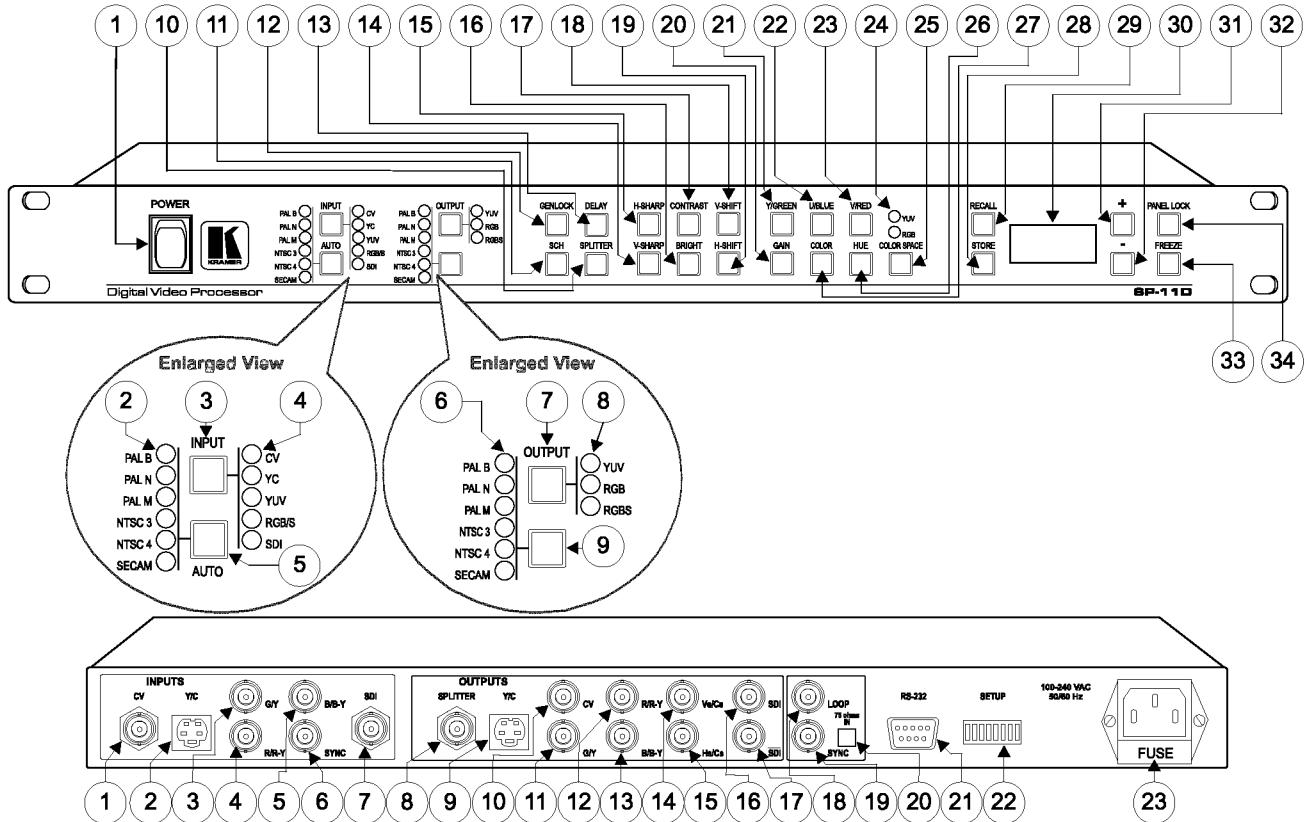

Figure 1: SP-11D Digital Video Processor



Table 1: Front Panel SP-11D Digital Video Processor

#	Feature	Function
1	POWER Switch	Illuminated switch for turning the unit ON or OFF
2	INPUT STANDARD LEDs	Cycle between PAL B, PAL N, PAL M, NTSC 3, NTSC 4, and SECAM. The corresponding LED lights
3	INPUT Selector Button	Press to select the source, illuminating the appropriate LED
4	INPUT LEDs	Cycle between the video sources: CV, YC, YUV, RGB/S, and SDI. The corresponding LED lights
5	AUTO Button	Toggles between automatically recognizing the input standard (lighting the appropriate LED) and the manual selection mode
6	OUTPUT STANDARD LEDs	Cycle between PAL B, PAL N, PAL M, NTSC 3, NTSC 4, and SECAM. The corresponding LED lights
7	(COMPONENT) OUTPUT Button	Selects the component video output signal
8	COMPONENT OUTPUT LEDs	Cycle between YUV, RGB, and RGBS. The corresponding LED lights
9	STANDARDS Button	Selects the output video standard
10	SPLITTER Button	Press the SPLITTER button and adjust the position of the boundary between the edited image and the original image, using the + and – buttons
11	SCH Button	Press the SCH button and adjust the subcarrier to horizontal phase relative to the Genlock source, using the + and – buttons
12	GENLOCK Button	Press to enable GENLOCK operation
13	DELAY Button	Press the DELAY ¹ button and adjust the H-delay of the output signal relative to the Genlock source, using the + and – buttons
14	V-SHARP Button	Press the V-SHARP button and adjust the vertical sharpness using the + and – buttons
15	H-SHARP Button	Press the H-SHARP button and adjust the horizontal sharpness using the + and – buttons
16	BRIGHTNESS Button	Press the BRIGHT button and adjust using the + and – buttons
17	CONTRAST Button	Press the CONTRAST button and adjust using the + and – buttons
18	V-SHIFT Button	Press the V-SHIFT button and adjust V-Chroma-Luma delay using the + and – buttons to enable vertical shifting of the image
19	H-SHIFT Button	Press the H-SHIFT button and adjust H-Chroma-Luma delay using the + and – buttons to enable horizontal shifting of the image
20	GAIN Button	Press the VIDEO GAIN button and adjust using the + ² and – ³ buttons
21	Y/GREEN Button	Press the Y ⁴ /GREEN ⁵ button ⁶ and adjust using the + and – buttons
22	U/BLUE Button	Press the U ⁴ /BLUE ⁵ button ⁶ and adjust using the + and – buttons
23	V/RED Button	Press the V ⁴ /RED ⁵ button ⁶ and adjust using the + and – buttons
24	YUV/RGB LEDs	Cycle between the different color spaces of color control: YUV and RGB. The corresponding LED lights

1 Data delay problems, especially with long cables, occur when electronic signals travel via coaxial cable and the picture shifts mainly in the horizontal axis (due to unequal delays between the sync signals and data). Center the picture by pressing the DELAY button and adjust via the + and – buttons

2 To add brightness

3 To fade the picture in and out

4 For YUV

5 For RGB

6 When the COLOR SPACE button is selected

Your SP-11D Digital Video Processor

#	Feature	Function
25	<i>COLOR SPACE</i> Button	Press to select the color space of the color control; if the <i>COLOR SPACE</i> button is not illuminated, color control is disabled
26	<i>HUE</i> Button	Press the <i>HUE</i> ¹ button and adjust using the + and – buttons
27	<i>COLOR</i> Button	Press the <i>COLOR</i> ² button and adjust using the + and – buttons
28	<i>STORE</i> Button	Stores the current setup in the non-volatile memory
29	<i>RECALL</i> Button	Recalls a setup from the non-volatile memory
30	7-segment Display	Displays data when using a front panel button
31	+ Button	Press to increase the level
32	- Button	Press to decrease the level
33	<i>FREEZE</i> Button	Pauses the output video
34	<i>PANEL LOCK</i> Button	Disengages the front panel buttons

Table 2: Rear Panel SP-11D Digital Video Processor

#	Feature	Function	
1	INPUTS	<i>CV</i> BNC Connector	Connects to the composite video source
2		<i>Y/C</i> 4p Connector	Connects to the s-Video source
3		<i>G/Y</i> BNC Connector	Connects to the RGB (connect all 3 connectors: G, B, and R), or YUV (connect all 3 connectors: Y, B-Y, and R-Y), or RGBS (connect all 4 connectors: G, B, R and S ³) video source
4		<i>R/R-Y</i> BNC Connector	
5		<i>B/B-Y</i> BNC Connector	
6		<i>SYNC</i> BNC Connector	Connects to the external video sync source
7		<i>SDI</i> BNC Connector	Connects to the SDI source
8	OUTPUTS	<i>SPLITTER</i> BNC Connector	Connects to the split image acceptor
9		<i>Y/C</i> 4p Connector	Connects to the s-Video (<i>Y/C</i>) acceptor
10		<i>CV</i> BNC Connector	Connects to the composite video acceptor
11		<i>G/Y</i> BNC Connector	Connects to the RGB (connect all 3 connectors: G, B, and R), or YUV (connect all 3 connectors: Y, B-Y, and R-Y), or RGBS (connect all 4 connectors: G, B, R and any Cs), or RGBHV (connect all 5 connectors: G, B, R, Hs and Vs) video acceptor
12		<i>R/R-Y</i> BNC Connector	
13		<i>B/B-Y</i> BNC Connector	
14		<i>Vs</i> (vertical sync)/ <i>Cs</i> ⁴ BNC Connector	
15		<i>Hs</i> (horizontal sync)/ <i>Cs</i> ⁴ BNC Connector	
16		<i>SDI</i> BNC Connector	Connects to the serial digital video acceptor 1
17		<i>SDI</i> BNC Connector	Connects to the serial digital video acceptor 2
18	<i>LOOP</i> BNC Connector	Connects to the next Genlocked unit	
19	<i>SYNC</i> BNC Connector	Connects to the Genlock source	
20	Term Button	Press to terminate the Genlock source (75Ω) or release for looping ⁵	
21	<i>RS-232</i> Port	Connects to the PC or the Remote Controller	
22	<i>SETUP</i> Dipswitches	Dipswitches setup (see section 6.2)	
23	Power Connector with <i>Fuse</i>	AC connector enabling power supply to the unit	

1 Available in all input and output formats and standards

2 Pressing the + button enhances dull colors. Pressing the – button reduces distortion (snow)

3 Item 6 below

4 To use Cs (Composite Sync), set Dipswitch 2 ON (see Table 3 for details)

5 Push in to terminate the input. Release when the input extends to another unit



5 Installing on a Rack

This section describes what to do before installing on a rack and how to rack mount.

Before Installing on a Rack

Before installing on a rack, be sure that the environment is within the recommended range:	
Operating temperature range	+5 to +45 Deg. Centigrade
Operating humidity range	5 to 65 % RHL, non-condensing
Storage temperature range	-20 to +70 Deg. Centigrade
Storage humidity range	5 to 95% RHL, non-condensing



CAUTION!!

When installing on a 19" rack, avoid hazards by taking care that:

- 1 It is located within the recommended environmental conditions, as the operating ambient temperature of a closed or multi unit rack assembly may exceed the room ambient temperature.
- 2 Once rack mounted, enough air will still flow around the machine.
- 3 The machine is placed straight in the correct horizontal position.
- 4 You do not overload the circuit(s). When connecting the machine to the supply circuit, overloading the circuits might have a detrimental effect on overcurrent protection and supply wiring. Refer to the appropriate nameplate ratings for information. For example, for fuse replacement, see the value printed on the product label.
- 5 The machine is earthed (grounded) in a reliable way and is connected only to an electricity socket with grounding. Pay particular attention to supply connections other than direct connections to the branch circuit (for example, the use of power strips), and that you use only the power cord that is supplied with the machine.

How to Rack Mount

To rack-mount the machine:

- 1 Attach both ear brackets to the machine. To do so, remove the screws from each side of the machine (3 on each side), and replace those screws through the ear brackets.

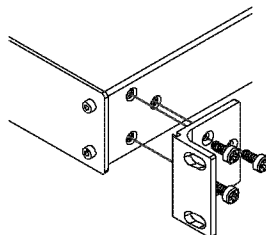

- 2 Place the ears of the machine against the rack rails, and insert the proper screws (not provided) through each of the four holes in the rack ears.

Note that:

- In some models, the front panel may feature built-in rack ears
- Detachable rack ears can be removed for desktop use
- Always mount the machine in the rack before you attach any cables or connect the machine to the power
- If you are using a Kramer rack adapter kit (for a machine that is not 19"), see the Rack Adapters user manual for installation instructions (you can download it at: <http://www.kramerelectronics.com>)

6 Connecting Your SP-11D Digital Video Processor

You can use your **SP-11D** to convert composite video, s-Video, component video (YUV or RGB/S), or SDI signals to composite video, s-Video, component video (YUV, RGsB, RGBS, RGBHV) and¹ SDI. The processing can be evaluated on a “Before/after” split-screen, as the example in Figure 3 illustrates.

To connect the **SP-11D Digital Video Processor**, do the following²:

1. Connect the following sources to the **SP-11D**:
 - The composite video source (for example, a VCR) to the CV INPUT BNC connector
 - The s-Video source (for example, an S-VHS) to the Y/C INPUT 4p connector
 - The SDI source (for example, a digital video player) to the SDI INPUT BNC connector
2. Connect the component video INPUTS BNC connectors, G/Y, B/B-Y, and R/R-Y to either a YUV or an RGB video source, as follows:
 - A Betacam VCR source to G/Y, R/R-Y, and B/B-Y, **or**
 - A camera (RGBS) source to G/Y, R/R-Y, B/B-Y and SYNC
3. Connect the following acceptors to the **SP-11D**:
 - The SPLITTER OUTPUT BNC connector to a composite video display
 - The Y/C OUTPUT 4p connector to an s-Video display
 - The CV OUTPUT BNC connector to a composite video display
 - The five BNC OUTPUTS connectors: G/Y, B/B-Y, R/R-Y, Vs/Cs, and Hs/Cs to a video acceptor (for example, a plasma display)
 - The two SDI OUTPUT BNC connectors to two serial digital video acceptors (for example, two displays: SDI 1 and SDI 2)
4. Connect the LOOP BNC connector to the next **SP-11D** Genlocked unit (if required) and release the Term button for looping³.
5. Connect a Genlock source to the SYNC BNC connector.
6. Connect a PC or other controller, if required (see section 6.1).
7. Set the dipswitches (see section 6.2).
8. Connect the power cord⁴ (not illustrated in Figure 3).

1 All output formats are always available. However, when only one output is required, connect that output of the SP-11D, and leave the other outputs unconnected

2 Switch OFF the power on each device before connecting it to your SP-11D. After connecting your SP-11D, switch on its power and then switch on the power on each device

3 Pushed in terminates the input. Release when the input extends to another unit

4 We recommend that you use only the power cord that is supplied with this machine

6.1 Connecting a PC

To connect a PC to the **SP-11D** unit, using the Null-modem adapter provided with the machine (recommended):

- Connect the RS-232 DB9 rear panel port on the **SP-11D** unit to the Null-modem adapter and connect the Null-modem adapter with a 9 wire flat cable to the RS-232 DB9 port on your PC

To connect a PC to the **SP-11D** unit, without using a Null-modem adapter:

- Connect the RS-232 DB9 port on your PC to the RS-232 DB9 rear panel port on the **SP-11D** unit, as Figure 2 illustrates

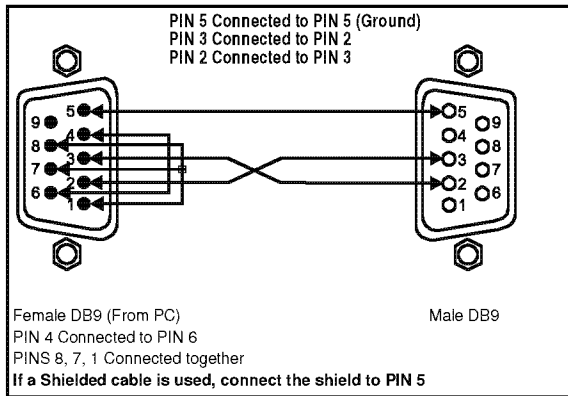

Figure 2: Connecting a PC without using a Null-modem Adapter

6.2 Dipswitch Settings

The **SP-11D** dipswitch settings are defined in Table 3 and Table 4:

Table 3: Dipswitch Settings

Dipswitch	Set as follows:
1	Pedestal ON for pedestal of output signal (7.5 IRE offset selection for NTSC); OFF for no pedestal
2	HsVs/Cs ¹ ON for Composite Sync on outputs Hs/Cs and Vs/Cs; OFF for Horizontal Sync on Hs/Cs, and Vertical Sync on Vs/Cs outputs
3	Secam VBI ON for insert identification signals occupying 9 lines of field-blanking period (only for SECAM output standard) (bottle pulses); OFF for no insert (no bottle pulses)
4,5,6	Test Signals The status of these dipswitches defines the test signal: see Table 4
7	AGC ON for enabling automatic gain control; OFF for disabling automatic gain control
8	ADDR For selecting one of two machine addresses (defining the machine address)

¹ See the rear panel items 15 and 14 in Figure 1 and Table 2

Table 4: Test Signals

FUNCTION	DIP 4	DIP 5	DIP 6
VITS 330 (Modulated Staircase) – full field mode	ON	ON	ON
No Signal ¹	OFF	OFF	OFF
Split 75% Bar Generator	ON	ON	OFF
VITS 18 (Multiburst 5.8MHz) – full field mode	ON	OFF	ON
Vertical 75% Bar Generator	ON	OFF	OFF
Inverse Horizontal 75% Bar Generator	OFF	OFF	ON
Horizontal 75% Bar Generator	OFF	ON	OFF
VITS 17 (2T, 20T, 5 Step Staircase) – full field mode	OFF	ON	ON

The example in Figure 3 illustrates how to connect your **SP-11D**:

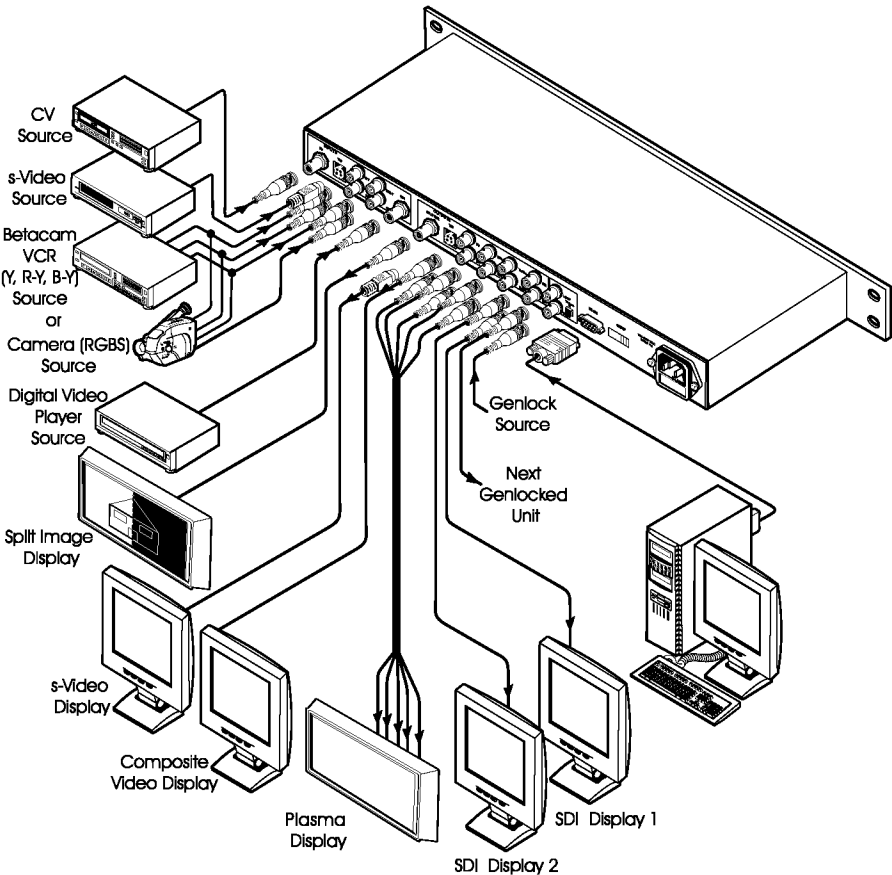

Figure 3: Connecting the SP-11D Digital Video Processor

¹ This is the Main mode; test signals are not available

7 Operating the SP-11D Digital Video Processor

Operate your **SP-11D Digital Video Processor** via:

- The front panel buttons
- RS-232 serial commands transmitted by a touch screen system, PC, or other serial controller

To operate the **SP-11D** using the front panel buttons, do the following:

1. Turn on the power and after it has completed its warm-up sequence, press the INPUT button to select the source—CV, YC, YUV, RGB/S, or SDI—that you want to convert.

The appropriate INPUT LED lights (indicating selection and conversion of that source).

2. When the AUTO button illuminates, the video standard corresponding to the selected input is detected automatically.

The appropriate INPUT STANDARD LED lights: PAL B, PAL N, PAL M, NTSC 3.58, NTSC 4.43 or SECAM¹.

When the AUTO button does not illuminate—that is, the **SP-11D** is in manual mode—select the desired video standard by pressing the AUTO button to cycle between the various video standards.

3. Press the (Component) OUTPUT button to select the component output signal format: YUV, RGB, or RGBS.

4. Press the STORE button twice to save the previous selection (power down saving: optional).

5. Press the STANDARDS button to select the output standard of the composite video signal.

The appropriate OUTPUT STANDARDS LED blinks as well as the STORE button. However, the output standard is not altered.

Press the STORE button once.

For 5 seconds no output video signal is available, and “rL” is displayed in the 7-segment display, indicating that the **SP-11D** is reloading.

After the reloading, the standard of the output video signal changes as well as that of the “Before/after” split-screen.

6. Press the GENLOCK button to enable the Genlock function.

If the SYNC BNC connector² is connected to a Genlock source, and the standard of the signal on this input coincides with the standard of the output video signal, the GENLOCK button will illuminate. If not, the GENLOCK button will blink.

¹ For example, when the composite source is selected, the PAL B INPUT STANDARD LED lights

² Item 19 in Table 2

7. Adjust the color¹, brightness, contrast, hue, sharpness², H-shift, V-shift³, (Delay, SCH if required for genlock) and/or the video gain of the picture, as follows:

- Press the appropriate button⁴

The button illuminates, and blinks, and the 7-segment display shows the current level (in digits)

The digit “0” corresponds to the normal level (“NORM”)

- Press the + button or – button once to gradually increase or decrease the current level by one unit (the 7-segment display shows the new level)

To increase or decrease the current level rapidly, press and hold down the + button or – button, continuously⁵. To end the rapid adjustment, release the + button or – button

Note, if you want to:

- Set the normal level (“NORM”) of the current level, press and simultaneously hold down both the + button and – button.

The 7-segment display shows “0”

- Undo the adjustment, press the appropriate button one more time. The appropriate button no longer blinks

- Save the result of the adjustment, press the STORE button twice

- Store the result of the adjustment in another setup #, press the STORE button once, select a setup # between 1 and 16 by pressing the + and – buttons, and then press the STORE button once again

If the adjustment is set such that the level setting is at its normal level (“NORM”), the appropriate button no longer illuminates (otherwise this button continues to illuminate in the main mode).

1 The SP-11D has a full range of color control features in both YUV and RGB colorspaces with independent control of RED, GREEN and BLUE; and Y, R-Y and B-Y

2 Using the V-SHARP and H-SHARP buttons

3 Using the V-SHIFT and H-SHIFT buttons

4 See the relevant items defined in Table 1

5 The 7-segment display starts to quickly scan the range. When it stops running, it has reached the maximum or minimum setting

7.1 Storing/Recalling Setups

You can store and recall up to 16 setups (or adjustments) in non-volatile memory, using the STORE and RECALL buttons together with the + and – buttons.

To store¹ a setup, do the following:

- Press the STORE button and then select a setup # between 1 and 16 by pressing the + and – buttons (the current settings are saved to that setup #)
- Press the STORE button once again

To recall a setup, do the following:

- Press the RECALL button and then select the appropriate # (that corresponds to the setup #) by pressing the + and – buttons (the selected setup is recalled)
- Press the RECALL button once again

7.2 Locking the Front Panel

To prevent changing the settings unintentionally or tampering with the front panel, lock your **SP-11D**. Unlocking releases the protection mechanism.

To lock the **SP-11D**:

- Press the PANEL LOCK button (for about 2 seconds) until it illuminates — freezing the front panel controls. Pressing a button will have no effect², except to cause the PANEL LOCK button to blink³ and show the value of a ProcAmp setting if its button is pressed⁴

To unlock the **SP-11D**:

- Press the PANEL LOCK button (for about 2 seconds) until the front panel controls unlock and the PANEL LOCK button no longer illuminates

1 Storing a new setup over a previous setup # replaces the previous setup #

2 Nevertheless, even though the front panel is locked you can still operate your PC control software

3 Warning that you need to unlock to regain control via the front panel

4 For example, if the HUE button is pressed when the panel is locked, then the 7-segment display will illuminate the current value of the HUE setting

8 Technical Specifications

Table 5 includes the technical specifications:

Table 5: Technical Specifications¹ of the SP-11D Video Processor

INPUTS:	1 composite video - 1 Vpp / 75Ω on a BNC connector 1 YC - 1 Vpp / 75Ω (Y), 0.3Vpp / 75Ω on a 4p connector 1 component - Y/R-Y/B-Y (1Vpp/0.7Vpp/0.7Vpp) /75Ω (or RGB/S) on BNC connectors 1 SDI: SMPTE-259M, ITU-R BT.601 on a BNC connector 1 SYNC (Genlock): Looped 75Ω / Hi-Z on BNC connectors
OUTPUTS:	1 composite video - 1 Vpp / 75Ω on a BNC connector 1 YC - 1 Vpp / 75Ω (Y), 0.3Vpp / 75Ω on a 4p connector 1 component - Y/R-Y/B-Y (1Vpp/0.7Vpp/0.7Vpp) /75Ω (or RGB/S) on BNC connectors 2 SDI: SMPTE-259M, ITU-R BT.601 on BNC connectors
VIDEO STANDARDS:	PAL-B/D/G/H/I/M/N, NTSC-3.58/4.43, SECAM
DIGITAL RESOLUTION:	10 bits
BANDWIDTH (-3dB):	0.5dB to 5MHz, Fully Loaded
DIFF. GAIN:	1%
DIFF. PHASE:	1%
K-FACTOR:	0.4%
S/N RATIO:	60dB
LUMA NON-LINEARITY:	1%
CHROMA / LUMA DELAY:	<15ns
MEMORY:	Non-volatile memory for storage of 16 setups
CONTROLS:	Front-panel and RS-232: Contrast, brightness, video gain, color, hue, H/V sharpness, SCH phase, delay, H/V shift; R, G, B, R-Y, B-Y level; screen splitter (process to bypass); freeze; panel lock
POWER SOURCE:	Universal, 100-240VAC, 50/60Hz
DIMENSIONS:	19 inch (W), 7 inch (D), 1U (H) rack mountable
WEIGHT:	2.6 kg. (5.7 lbs.) approx.
ACCESSORIES:	Power cord, Null-modem Adapter

¹ Specifications are subject to change without notice



9 Communication Protocol

This protocol, which enables RS-232 communication between the **SP-11D** and the PC, uses 4 bytes of information, and data is at 9600 baud.

Table 6: Protocol Definitions

First byte options

	DEC	HEX	
1	128	80	RESET VIDEO
2	160	A0	READ PARAMETER
3	161	A1	WRITE PARAMETER
4	162	A2	RECALL
5	163	A3	STORE
6	189	BD	IDENTIFY MACHINE
7	33	21	Set (for the rest of commands)
Second byte is the command type			
Third byte is the parameter value			

Note:

1. When working in HEX, add 80 to the values in the table.
2. When working in DEC, add 128 to the values in the table.
3. All values in the table are in DEC.

Byte 2	Command Description	Byte 3 (parameter value)
0	INPUT FORMAT	0 - CV 1 - YC 2 - YUV 3 - RGB/S 4 - SDI
1	INPUT_STANDARD	0 - PAL B 1 - PAL N 2 - PAL M 3 - NT 3 4 - NT 4 5 - SEC 6 - AUTO
	(READ 19 - INPUT_STANDARD_AUTO)	
2	SPLITTER	-100 - +100
3	SHARP_H	0 - 15
4	SHARP_V	0 - 15
5	CONTRAST	-100 - +100
6	BRIGHTNESS	-100 - +100
7	VIDEO_GAIN	-100 - +100
8	H_SHIFT	-16 - +15
9	V_SHIFT	-1 - +1
10	Y	-100 - +100
11	U	100 - +100
12	V	100 - +100
13	GREEN	-100 - +100
14	BLUE	-100 - +100
15	RED	-100 - +100
16	COLOR	-100 - +100
17	HUE	-100 - +100
18	COLOR_SPACE	0 - OFF 1 - YUV 2 - RGB
19	INPUT_STANDARD_AUTO	(READ ONLY) 0 - PAL B 1 - PAL N 2 - PAL M 3 - NT 3 4 - NT 4 5 - SEC

Communication Protocol

	GLOBAL	
20	OUTPUT_FORMAT	0 - YUV 1 - RGB
		2 - RGBS
21	OUTPUT_STANDARD	0 - PAL B 1 - PAL N 2 - PAL M 3 - NT 3 4 - NT 4 5 - SEC
22	GENLOCK	0 - OFF 1 - ON
23	PANEL_LOCK	0 - OFF 1 - ON
24	SCH	-100 - +100
24	DELAY	-100 - +100
26	FREEZE	0 - OFF 1 - ON
27	PROGRAM	0 - 15 (read only)
28	GENLOCK_STAT	(Read only) 0 - No GENLOCK 1 - GENLOCK

Byte 4 is the machine address: can be 98 or 99 (in HEX).

First byte = I

Second byte=D

Third byte=E

MACHINE TO PC:

	MACHINE POWER-UP
PC <- I = 34;D = 0;E = PROGRAMM NUMBER <- MACHINE (RECALL)	PRESS OF "RECALL"
PC <- I = 34;D = 0;E = PROGRAMM NUMBER <- MACHINE (RECALL)	PRESS OF "STORE"
PC <- I = 34;D = 0;E = PROGRAMM NUMBER <- MACHINE (RECALL)	CHANGE "OUTPUT_STANDARD"
PC <- I = 34;D = 0;E = PROGRAMM NUMBER <- MACHINE (RECALL)	CHANGING OTHER KEYS
PC <- I = 33;D = PARAMETER NUMBER; E = PARAMETER <- MACHINE (PARAMETER WRITE)	

PC TO MACHINE:

	RESET VIDEO
	POWER-UP(PSEUDO)
PC -> I = 0;D = 0;E = 0 -> MACHINE	
PC <- I = 0;D = 0;E = 0 <- MACHINE	
	DEFAULT
PC -> I = 0;D = 1;E = 0 -> MACHINE	
WRITE EEPROM ALL PARAMETERS - DEFAULT (ALL PROGRAMS),RELOAD (RESTART)	
PC <- I = 34;D = 0;E = PROGRAMM NUMBER <- MACHINE (RECALL)	
	PARAMETER READ
PC -> I = 32;D = PARAMETER NUMBER;E = 0 -> MACHINE	
PC <- I = 32;D = PARAMETER NUMBER;E = PARAMETER <- PARAMETER	
	PARAMETER WRITE
PC -> I = 33;D = PARAMETER NUMBER;E = PARAMETER -> MACHINE	
PC <- I = 33;D = PARAMETER NUMBER;E = PARAMETER <- MACHINE	
	WRITE OUTPUT_STANDARD
PC -> I = 33;D = 21;E = PARAMETER -> MACHINE MACHINE RELOAD (RESTART)	
PC <- I = 34;D = 0;E = PROGRAMM NUMBER <- MACHINE (RECALL)	
	RECALL
PC -> I = 34;D = 0;E = PROGRAMM NUMBER -> MACHINE	
PC <- I = 34;D = 0;E = PROGRAMM NUMBER <- MACHINE	
PROGRAMM NUMBER - 0 = PROGRAMM 1	
PROGRAMM NUMBER - 1 = PROGRAMM 2	
PROGRAMM NUMBER - 15 = PROGRAMM 16	

Communication Protocol

STORE

PC -> I = 35;D = 0;E = PROGRAMM NUMBER -> MACHINE
PC <- I = 34;D = 0;E = PROGRAMM NUMBER <- MACHINE (RECALL)
IDENTIFY MACHINE
MACHINE NAME
PC -> I = 61;D = 1;E = 0 -> MACHINE
PC <- I = 61;D = MACHINE NAME HIGH;E = MACHINE NAME LOW <- MACHINE
SOFTWARE VERSION
PC -> I = 61;D = 3;E = 0 -> MACHINE
PC <- I = 61;D = SOFTWARE VERSION HIGH;E = SOFTWARE VERSION LOW <- MACHINE

Examples:

1. Select CV input format:

H21 H80 H80 H98

Unit response:

H61 H80 H80 H98

2. Reset:

H80 H80 H80 H98

3. Recall set up 1:

HA2 H80 H80 H98

DEC: 162 128 128 152

4. Store set up 2:

HA3 H80 H81 H98

DEC: 162 128 129 152

LIMITED WARRANTY

Kramer Electronics (hereafter *Kramer*) warrants this product free from defects in material and workmanship under the following terms.

HOW LONG IS THE WARRANTY

Labor and parts are warranted for seven years from the date of the first customer purchase.

WHO IS PROTECTED?

Only the first purchase customer may enforce this warranty.

WHAT IS COVERED AND WHAT IS NOT COVERED

Except as below, this warranty covers all defects in material or workmanship in this product. The following are not covered by the warranty:

1. Any product which is not distributed by Kramer, or which is not purchased from an authorized Kramer dealer. If you are uncertain as to whether a dealer is authorized, please contact Kramer at one of the agents listed in the web site www.kramerelectronics.com.
2. Any product, on which the serial number has been defaced, modified or removed.
3. Damage, deterioration or malfunction resulting from:
 - i) Accident, misuse, abuse, neglect, fire, water, lightning or other acts of nature
 - ii) Product modification, or failure to follow instructions supplied with the product
 - iii) Repair or attempted repair by anyone not authorized by Kramer
 - iv) Any shipment of the product (claims must be presented to the carrier)
 - v) Removal or installation of the product
 - vi) Any other cause, which does not relate to a product defect
 - vii) Cartons, equipment enclosures, cables or accessories used in conjunction with the product

WHAT WE WILL PAY FOR AND WHAT WE WILL NOT PAY FOR

We will pay labor and material expenses for covered items. We will not pay for the following:

1. Removal or installations charges.
2. Costs of initial technical adjustments (set-up), including adjustment of user controls or programming. These costs are the responsibility of the Kramer dealer from whom the product was purchased.
3. Shipping charges.

HOW YOU CAN GET WARRANTY SERVICE

1. To obtain service on you product, you must take or ship it prepaid to any authorized Kramer service center.
2. Whenever warranty service is required, the original dated invoice (or a copy) must be presented as proof of warranty coverage, and should be included in any shipment of the product. Please also include in any mailing a contact name, company, address, and a description of the problem(s).
3. For the name of the nearest Kramer authorized service center, consult your authorized dealer.

LIMITATION OF IMPLIED WARRANTIES

All implied warranties, including warranties of merchantability and fitness for a particular purpose, are limited in duration to the length of this warranty.

EXCLUSION OF DAMAGES

The liability of Kramer for any effective products is limited to the repair or replacement of the product at our option. Kramer shall not be liable for:

1. Damage to other property caused by defects in this product, damages based upon inconvenience, loss of use of the product, loss of time, commercial loss; or:
2. Any other damages, whether incidental, consequential or otherwise. Some countries may not allow limitations on how long an implied warranty lasts and/or do not allow the exclusion or limitation of incidental or consequential damages, so the above limitations and exclusions may not apply to you.

This warranty gives you specific legal rights, and you may also have other rights, which vary from place to place.

NOTE: All products returned to Kramer for service must have prior approval. This may be obtained from your dealer.

This equipment has been tested to determine compliance with the requirements of:

- EN-50081: "Electromagnetic compatibility (EMC);
generic emission standard.
Part 1: Residential, commercial and light industry"
- EN-50082: "Electromagnetic compatibility (EMC) generic immunity standard.
Part 1: Residential, commercial and light industry environment".
- CFR-47:
FCC Rules and Regulations:
Part 15: "Radio frequency devices
Subpart B – Unintentional radiators"

CAUTION!

- ☒ Servicing the machines can only be done by an authorized Kramer technician. Any user who makes changes or modifications to the unit without the expressed approval of the manufacturer will void user authority to operate the equipment.
- ☒ Use the supplied DC power supply to feed power to the machine.
- ☒ Please use recommended interconnection cables to connect the machine to other components.





For the latest information on our products and a list of Kramer distributors, visit our Web site: www.kramerelectronics.com, where updates to this user manual may be found. We welcome your questions, comments and feedback.

 <p>Caution</p>	<p>Safety Warning: Disconnect the unit from the power supply before opening/servicing.</p>
---	---



Kramer Electronics, Ltd.
Web site: www.kramerelectronics.com
E-mail: info@kramerelectronics.com
P/N: 2900-003112 REV 2