

TRUSS KRATOWNICE

Main tube/ Rura główna **48x3mm**

Braces/ lamelka **16x2mm**

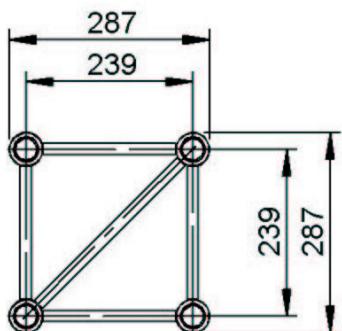

Truss
kratownica

Product Code
Kod produktu

Length
długość

Weight
waga



ALC34050

0,5m

3,8
kg

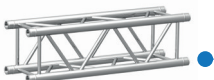

ALC34100

1,0m

6,7
kg



ALC34150

1,5m

9,5
kg

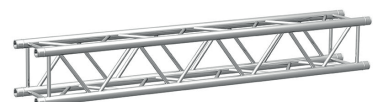

ALC34200

2,0m

12,3
kg

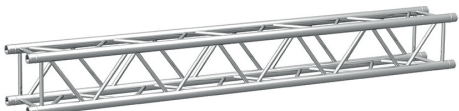

ALC34250

2,5m

15,2
kg

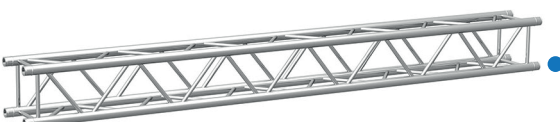

ALC34300

3,0m

18,11
kg



ALC34350

3,5m

20,0
kg

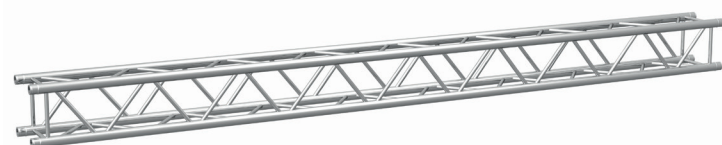

ALC34400

4,0m

23,3
kg

Load chart
according static calculation

Alustage QUA 290 B

Partial factors
Self weight 1,35
User loads 1,5

User loads

Span	Uniformly Distributed load		Centre Point load		Third Point load		Quarter Point load		5th Point load	
Stützweite	Gleichlast		Mittige Punktlast		Last in Drittelunkten		Last in Viertelpunkten		Last in Fünftelpunkten	
m	kg/m	mm	kg	mm	kg (2x)	mm	kg (3x)	mm	kg (4x)	mm
2	903,8	1,5	1807,5	2,4	903,8	2,0	602,5	1,9	451,9	1,8
3	600,9	5,0	1543*	6,8	901,4	6,8	600,9	6,3	450,7	6,0
4	449,5	11,8	1177,1	12,3	839*	14,9	588,5	14,6	449,5	14,2
5	358,6	23,0	937,4	19,3	703,0	24,6	468,7	22,9	390,6	24,2
6	258,9	34,7	776,8	27,9	582,6	35,4	388,4	33,0	323,6	34,9
7	189,0	47,2	661,4	38,0	496,0	48,2	330,7	44,9	275,6	47,6
8	143,6	61,7	574,2	49,8	430,7	63,0	287,1	58,7	239,3	62,2
9	112,4	78,2	505,9	63,2	379,4	79,8	253,0	74,4	210,8	78,8
10	90,2	96,6	450,8	78,4	338,1	98,6	225,4	92,0	187,8	97,3
11	73,7	117,0	405,3	95,2	303,9	119,5	202,6	111,6	168,9	117,9
12	61,2	139,5	366,9	113,8	275,2	142,3	183,5	133,0	152,9	140,5
13	51,4	163,9	334,1	134,2	250,6	167,2	167,0	156,5	139,2	165,1
14	43,7	190,4	305,6	156,4	229,2	194,1	152,8	181,9	127,3	191,7
15	37,4	218,9	280,6	180,5	210,5	223,1	140,3	209,3	116,9	220,4
16	32,3	249,5	258,5	206,6	193,9	254,2	129,2	238,7	107,7	251,2
17	28,1	282,1	238,6	234,7	179,0	287,4	119,3	270,3	99,4	284,0
18	24,5	316,9	220,8	264,8	165,6	322,7	110,4	303,9	92,0	319,0

High values of distributed loads are idealized. Loads must be applied to knot points!

* limited by interaction of shear and moment at the connection
Displacement connection is decisive!